

FIG.38

F - 11

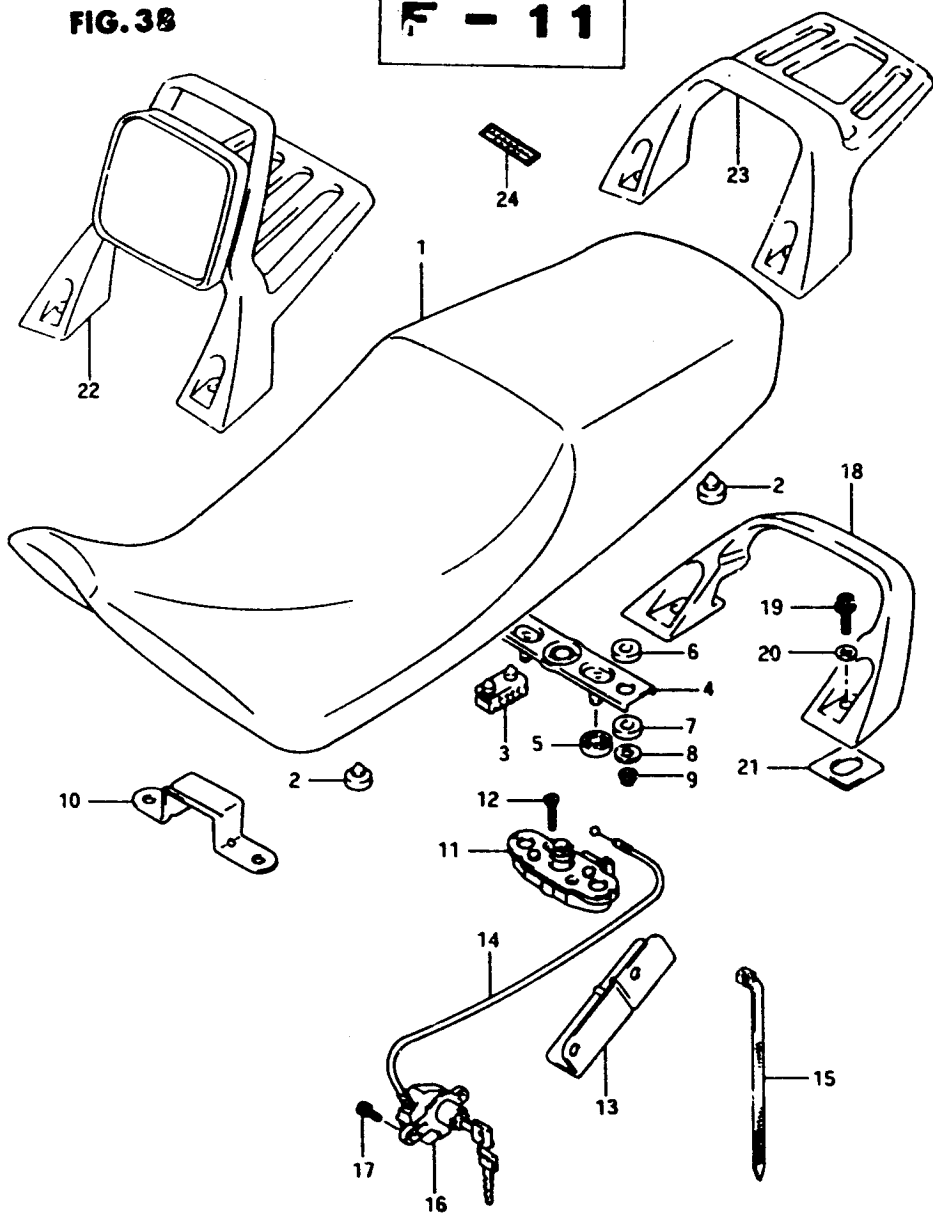

FIG.38 (F-11) SEAT

| REF.NO. | PART NO. | DESCRIPTION | Q'TY | REMARKS |
|---------|-----------------|--------------------------------|------|---|
| 1-1 | 45100-45C00-58R | SEAT SET (Black) | 1 | E2,E4,E15,E16,E17,E21, E22,E24,E25,E34 |
| 1-2 | 45100-45C10-58R | SEAT SET (Black) | 1 | E1,E18,E39 |
| 2 | 09321-10015 | .CUSHION | 4 | |
| 3 | 45149-31300 | .CUSHION, center | 2 | |
| 4 | 45215-22A00 | .STRIKER, seat lock | 1 | |
| 5 | 45213-13601 | .CUSHION, boss | 2 | |
| 6 | 45126-41800 | .CUSHION, striker upper | 2 | |
| 7 | 45127-41800 | .CUSHION, striker lower | 2 | |
| 8 | 08212-06201 | .WASHER | 2 | |
| 9 | 08316-26066 | .NUT | 2 | |
| 10 | 45119-45C00 | PLATE, front hook | 1 | |
| 11-1 | 45220-20A00 | BRACKET, seat support | 1 | model L/M/N |
| 11-2 | 45220-20A01 | BRACKET, seat support | 1 | model P/R |
| 12 | 02122-06303 | SCREW | 2 | |
| 13 | 45288-45C00 | PLATE, seat lock cable | 1 | |
| 14 | 45280-45C00 | CABLE, seat lock | 1 | |
| 15 | 09407-18402 | CLAMP | 1 | |
| 16 | 45700-19840 | LOCK SET, seat | 1 | |
| 17-1 | 09106-06055 | BOLT | 2 | model L/M/N/P |
| 17-2 | 07130-06123 | BOLT | 2 | model R |
| 18-1 | 46211-45C01-24D | HANDLE, pillion rider (Maroon) | 1 | model L/N |
| 18-2 | 46211-45C01-24V | HANDLE, pillion rider (Blue) | 1 | model L |
| 18-3 | 46211-45C01-33J | HANDLE, pillion rider (Black) | 1 | model L/M/N/P |
| 18-4 | 46211-45C01-0FP | HANDLE, pillion rider (Silver) | 1 | model M |
| 18-5 | 46211-45C01-19A | HANDLE, pillion rider (Red) | 1 | model M |
| 18-6 | 46211-45C01-1HU | HANDLE, pillion rider (Purple) | 1 | model N |
| 18-7 | 46211-45C01-22U | HANDLE, pillion rider (Maroon) | 1 | model P/R |
| 18-8 | 46211-45C01-1TU | HANDLE, pillion rider (Purple) | 1 | model R |
| 19-1 | 07120-10255 | BOLT | 2 | model L/M/N |
| 19-2 | 07130-10308 | BOLT | 2 | model P/R |
| 20-1 | 08322-11104 | WASHER | 2 | model L/M/N/P |
| 20-2 | 08322-01103 | WASHER | 2 | model R |
| 21 | 47161-45C00 | CUSHION, frame cover | 2 | |
| 22 | 46300-45811-23S | CARRIER SET, sport (Silver) | 1 | OPT |
| 23 | 46300-45821-23S | CARRIER, sport (Silver) | 1 | OPT |
| 24 | 68391-14000 | .LABEL | 1 | OPT |