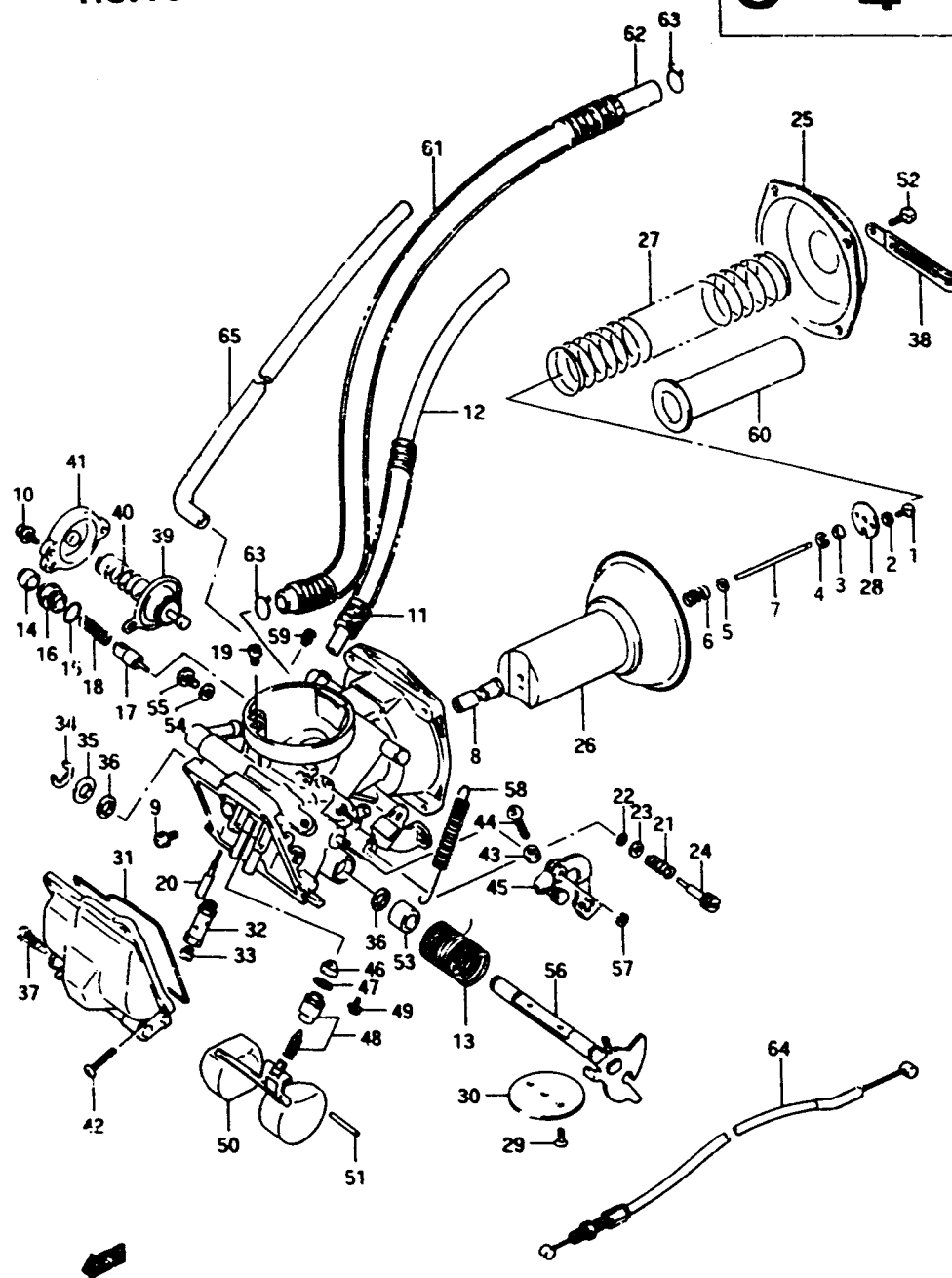

FIG. 10

C - 4

15

FIG. 10 (C - 4) CARBURETOR (FRONT)



REF. NO.	PART NO.	DESCRIPTION	QTY	REMARKS
40-1	13481-45C10	.SPRING	1	
40-2	13481-37300	.SPRING	1	E18
41	13484-45C00	.COVER	1	
42	13601-04148	.SCREW	4	
43	13607-05A10	.NUT	1	
44	02112-04306	.SCREW	1	
45	13554-38B10	.LEVER ASSY	1	+13554-45C10
46	13376-84110	.FILTER	1	
47	13374-44080	.O RING	1	
48	13370-38B00	.VALVE ASSY, needle	1	
49	13602-05A10	.SCREW	1	
50	13250-38B00	.FLOAT	1	
51	13254-20010	.PIN, float	1	
52	02112-05126	.SCREW	4	
53	13574-45C00	.RING	1	
54	13523-46110	.WASHER	1	EXCEPT E18
55	02112-05066	.SCREW	1	EXCEPT E18
56	13550-38B00	.SHAFT ASSY, throttle	1	+13550-45C10
57	13298-49000	.E RING	1	
58	13573-38B30	.SPRING	1	
59-1	09493-24007	.JET, pilot air (1.2)	1	
59-2	09493-26004	.JET, pilot air (1.3)	1	E18
60	13485-45C00	.RING	1	E17,E18,VX800UL/UM/UN/UP E22
61	13684-45C00	HOSE	1	
62	09354-65113-600	HOSE, fuel (6.5x11.5x600)	1	L:600-450
63	13671-38B00	CLIP	2	
64	13641-38B01	CABLE, 10 syncro	1	+13641-38B00
65	13218-45C00	HOSE ASSY	1	E18

Note : The component part for VX800UR E22 spec. will be announced later by supplementary issue. So please do not use the parts number for VX800UR E22 spec. in this page.

VX800R E2

AIR CLEANER.....	C-8	CYLINDER.....	B-6	FUEL COCK.....	F-10	OPTIONAL.....	H-12	SEAT.....	F-11	WIRING HARNESS.....	E-16
BATTERY.....	E-4	CYLINDER HEAD.....	B-2	FUEL TANK.....	F-3	PROPELLER SHAFT.....	D-9	SECOND DRIVE GEAR.....	D-6		
CAN CHAIN.....	R-12	ELECTRICAL.....	E-5	GEAR.....	D-7	RADIATOR.....	C-13	SPEEDOMETER.....	E-6		